



# AUDACITY® WATER RESISTANT LAMINATE FLOORING 12mm

## INSTALLATION INSTRUCTIONS

Materials shall be installed in accordance with AUSTRALIAN TIMBER FLOORING ASSOCIATION (ATFA)

LAMINATE FLOORING INDUSTRY STANDARD and these Armstrong Installation Instructions

**Please read and follow all instructions before you begin the installation.**

### Introduction

#### Floating Floor Structure

Audacity® Water Resistant Laminate Flooring is considered a “floating floor” and is installed using a floating floor system. These floors are intended for indoor use only and can be installed over virtually any existing floor structure. Like most materials this floor may expand and contract with changes in heat and relative humidity, therefore the use of an expansion gap of 10.00mm will be required. These expansion gaps will be covered when the skirting is replaced or new skirting is installed. If the skirting’s are left in place, a molding system will be required to cover the expansion gap.

Do not

- Attach to the subfloor at any point
- Install cabinets or island benches over the top of the flooring
- Fit flush against any fixed vertical surfaces like walls, permanent fixtures, door frames, pipes or staircases.

For Audacity® Water Resistant Laminate Flooring installation, the Sub floor preparation should follow the requirements as set in the ATFA Laminate Flooring Industry Standard and these Armstrong Flooring installation instructions.

#### Important Notice:

All wood based products, even those specifically designed to have increased resistance to moisture are hygroscopic (they will react to moisture in the environment), as a result will expand or contract accordingly. All sources of underfloor moisture must be rectified prior to the installation of the floor. Any construction dampness must be completely dry.

Audacity® laminate flooring is water resistant, not waterproof.

What does water resistant mean?

When properly installed, the floor will not be damaged by topical, localised spills resulting from normal household use, such as wet shoes and liquid spills, provided they are removed within 72 hours. **Please Note:** flooding or standing water must be avoided at all times and must be cleaned up immediately. (Audacity<sup>®</sup> is not recommended for installation in bathrooms)

### **Installer Responsibility**

Product inspection: Prior to installation, the installer has responsibility for final inspection as to manufacture and factory finish of the product. It is important that you check each plank for any manufacturing defects, any faults must be reported back to the store of purchase for an immediate refund or replacement prior to the flooring being installed.

The installer must use reasonable selectivity and hold out or cut off pieces with deficiencies, whatever the cause, should any individual piece be doubtful, the installer should not use the piece.

Carefully examine flooring for colour, finish and quality before installing it. If material is not acceptable, do not install it and contact the seller immediately.

Site inspection: Prior to installation, the installer must determine that the job-site environment and the subfloors involved meet or exceed all applicable standards.

Recommendations of the construction and materials industries as well as local statutory codes must be followed. These instructions recommend that the construction and subfloor be dry, hard, structurally sound and flat.

The manufacturer declines any responsibility for job failure resulting from, or associated with subfloor and substrates or job-site environmental deficiencies.

Use of stain, filler or putty stick for touch-up and appropriate products for correcting subfloor voids is accepted as part of normal installation procedures.

### **Subfloors:**

The condition of the subfloor not only has an important bearing on the appearance of the finished installation, but can dramatically affect the life and serviceability of the Audacity<sup>®</sup> Water Resistant Laminate Flooring. It is essential therefore that the subfloor should be dry, hard, rigid, smooth, level, clean and free of dust, grease and or any other contaminants.

Audacity<sup>®</sup> Water Resistant Laminate Flooring can be installed over most existing fully adhered, structurally sound substrates, including hard floor covering surfaces like Vinyl, linoleum and ceramic tiles. Ceramic tile joints should be smoothed with a levelling compound and the ceramic tile surface be within the planeness tolerance requirements (see below).

**Carpet or other soft flooring products are not suitable substrates.**

**Planeness:** All subfloors need to be sufficiently flat to accept a floating floor, when a two metre straightedge is at rest at two points on any part of the floor, there is to be no more than a 3mm gap under the straightedge. Installing Audacity<sup>®</sup> Water Resistant Laminate

Flooring over subfloors that do not meet the specific planeness requirements could lead to locking system failure, and will not be covered by the product warranty.

### **Concrete Subfloors:**

Concrete subfloors must be cured and completely dry. The surface must be steel trowelled to a smooth dense porous surface free of trowel marks, irregularities and undulation.

Concrete slabs in contact with fill, hard-core or the ground must have a damp-proof membrane to prevent entry of moisture. Water proofing additives and curing compounds do not negate the need for a damp-proof membrane. New concrete slabs will dry at an approximate rate of 1.00mm per day, to be measured from the time the slab was last wet e.g. 100mm slab will take 100 days to dry. This will vary depending on weather conditions and the surface of the concrete, e.g. A burnished concrete surface will take longer to dry.

Although Audacity<sup>®</sup> Water Resistant Laminate Flooring is water resistant, it is not designed to be used in areas that have a risk of flooding such as bathrooms, saunas or outdoor areas.

***A MOISTURE TEST SHOULD ALWAYS BE CARRIED OUT AND THE RESULTS RECORDED IN ACCORDANCE WITH THE AUSTRALIAN STANDARD 1884-2012 APPENDIX A PRIOR TO INSTALLATION***

Armstrong Flooring recommend the use of a 200µm polyethylene plastic sheeting to provide a vapour barrier, joins are to be overlapped by 200mm and taped using a waterproof tape. The plastic sheeting should extend up the wall and be trimmed to the top side of the floor after the installation has been completed and before installing the trim.

Note: Audacity<sup>®</sup> flooring comes with a factory attached pad to the back of planks, so no additional underlayment is required.

This product can be installed over radiant heating systems by following the instructions below.

1. Ensure the radiant heat surface temperature never exceeds 27°C.
2. Before installing over newly constructed radiant heat systems, operate the system at maximum capacity to force any residual moisture from the cementitious topping of the radiant heat system.
3. Shut down the floor heating at least 48 hours prior to installation and make sure that the temperature in the room is at least 18°C during installation.
4. It is recommended that the radiant heat be applied in a gradual manner after installing the floor. Refer to the radiant heat system's manufacturer recommendations for additional guidance.

### **Timber Subfloor:**

All timber subfloors (including tongue & groove, particle board & plywood) must have at least 450mm of good cross ventilation under the floor to prevent distortion and movement of flooring members. Timber subfloors should be rigid, sound, and free from excessive moisture, cupping and warping and constructed to relevant building standards.

Old timber subfloors should have all loose boards re-nailed and badly worn or damaged boards must be replaced.

Sand timber floors to a flat smooth finish without undulations before installing Audacity<sup>®</sup> Water Resistant Laminate Flooring. Planeness is to be no more than 3mm gap under a 2 meter straightedge at rest on any part of the timber floor.

When installing over a wood substrate we recommend using a 0.2mm (200 micron) polyethylene plastic sheeting as a vapour barrier, must be installed, overlap and tape joints by 200mm using a waterproof tape. The plastic sheeting should extend up the wall and be trimmed to the top side of the floor after the installation has been completed and before installing the trim.

### **Conditioning:**

Before commencing installation, keep the boards at room temperature for at least 48 hours in unopened cartons. The room temperature must be between 18-32°C and the relative humidity should be maintained between 30-65% before, during and after the installation.

### **PRE-INSTALLATION CHECKLIST**

It is the responsibility of the installer to check the material before installing:

- Is this the correct:
  - Product?
  - Colour?
  - Pattern?
  - Dimensions
- Does this stock match the customer's expectations?
- Have you read and are you following the installation recommendations?
- Has the product been allowed time to condition for 48 hours before the installation

In a well-lit area inspect the Audacity<sup>®</sup> Water Resistant Laminate Flooring material for visible surface or locking system defects prior to installation.

Any defects must be reported back to the store of purchase for an immediate replacement or refund.

Claims relating to surface / visual defects may not be accepted after installation. Contact your retailer if you have any concerns.

### **LAYOUT**

Calculate the room size prior to installation, allowing an extra 10% of flooring for cutting waste. Install Audacity<sup>®</sup> Water Resistant Laminate Flooring toward the main light source (e.g. large windows or of incoming light from any windows) or, if the lighting is not a concern, parallel to the longest wall in the room (Fig.2).

The direction of the boards should be confirmed with the consumer before commencing the installation.

Plan the job to have as large a cut piece as possible (minimum 50 mm) in the last row opposite the starting wall of the room, you may need to scribe the first row to the starting wall to achieve this.

**NOTE:** The use of expansion joints is not required for floor areas up to 400 m<sup>2</sup>, however no single dimension (width or length) in one area should exceed 20 meters in one direction.

## PREPARATION

1. The best option is to remove the existing skirting's, quarter round or scotia trim before installing the Audacity® Water Resistant Laminate Flooring. If this is not possible a molding will be needed to cover the required 10 mm expansion gap around the edges
2. Door trims and doorjamb's must be undercut to allow the floor to move freely. Use a discarded piece of floor Audacity® Water Resistant Laminate Flooring to support the saw blade at the correct height for undercutting. See figure 1
3. The bottom of the doors may also need to be adjusted to clear the Audacity® Water Resistant Laminate Flooring.
4. Sweep / vacuum the subfloor to remove all dust and debris.
5. Install the 0.2mm (200 micron) polyethylene plastic sheeting, overlapped by 200mm and tape using a waterproof tape.

Note: Audacity® flooring comes with a factory attached pad to the back of planks, so no additional underlayment is required (installation on additional underlay is not covered by warranty).

Figure: 1

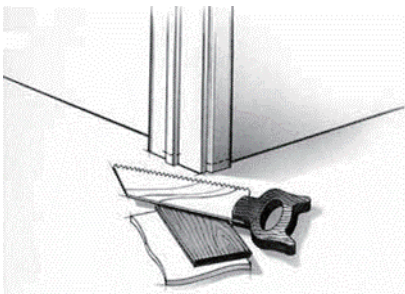
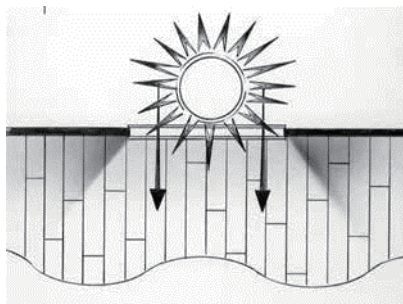

Figure: 2



**For the best result, make sure to always work from 2 to 3 cartons at a time mixing the planks during the installation**

## Required Cutting Tools

1. Appropriate PPE, hearing protection, dust protection.
2. A drop saw and table saw with a quality 60 tooth carbide-tipped cutting blade. a Jig saw with a fine blade.
3. When using power saws, the direction of blade must cut into the decorative side of the board to minimize chipping. If using a hand saw, cut with the decorative side of the board facing up.
4. Mark the board using a square to keep your cut line straight.
5. Set up the cutting station and cut in another area to keep the sawdust away from the installation site.

## Other tools

1. Carpenters square and long straightedge
2. Pencil / tape measure
3. Utility knife for trimming plastic
4. Spacers to maintain expansion gap around the edge
5. Bradding gun to fix skirtings or quads/ mouldings
6. Vacuum cleaner / broom / broom and dustpan
7. White rubber mallet

## INSTALLING THE FIRST ROW

1. Begin on the left side of the room and work towards the right.
2. Lay the first full piece with the small, tongue side facing the wall.
3. Install second and subsequent full pieces in the first row by aligning short ends of boards and locking into place (see figure 3).
4. Use spacers along all sides that butt up against walls to maintain 10.0 mm expansion gap (see figure 3).
5. Continue laying boards in the first row until you need to cut the last piece.
6. Measure the distance between the wall and the face surface of the last board. Subtract 10 mm and cut the board using the drop saw. (See cutting instructions above and figure 4),
7. If this distance is less than 300 mm go back to the first full plank and cut approximately 300 mm from the end closest to the starting wall. This will leave a longer piece at the end of the first row.

Figure: 3

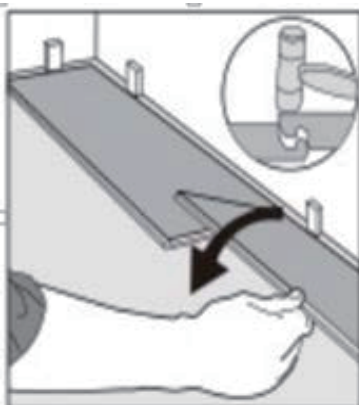

Figure: 4

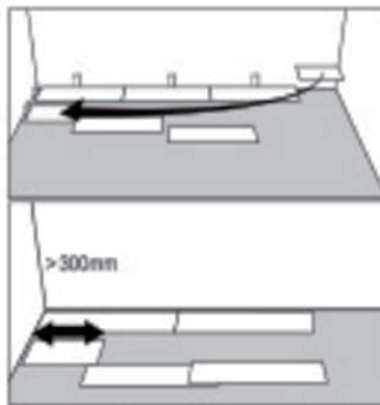
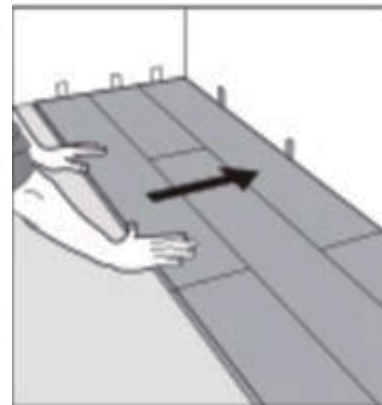

Figure: 5



## INSTALLING REMAINING ROWS

1. Begin the second row of planks with the piece cut from the last piece in the first row. If the piece is shorter than 300mm cut a new plank in half and use it to begin the second row. Whenever practical, use the piece cut from the preceding row to start the next row. End joints of all boards should be staggered 300mm or more.
2. Click the long side of the plank into the previous row and place it tight to the short end of the previous plank. Drop the plank and gently tap down the end with a rubber mallet so it firmly locks into the previous plank until both are at the same height. Make sure both planks are perfectly aligned and locked into the previous row leaving no gap. See figure 5 (Note: a tapping block may be required).

3. NOTE: If you notice both planks aren't at the same height or are not well locked together, please follow the disassembling instructions at the bottom of the page, disassemble and check if any debris stuck inside the lock is obstructing. Continue installing full boards in the second row by angling the short end of the next board in the row to lock into the previous board. Position the board so that the long side of the board is close to boards in the previous row and overlapping the groove of the boards in the previous row. Avoid any gapping between the planks, as any gapping can compromise the whole installation.
4. Continue installing full boards in the second and subsequent rows until you reach the wall on your right.
5. Mark the last piece, cut and install. It may be necessary to use a pull bar to ensure end joints are tight.
6. After all boards in the row are installed, press or walk all boards flat to the subfloor before beginning the next row. A tapping block may be used to fully engage the planks.
7. To make holes for pipes, measure the diameter and position of the pipe, drill the hole approximately 10 mm larger than the diameter of the pipe. To allow piece to be installed, cut a piece from the back side of the pipe using a slight 'v' shape. Sit piece into place, insert the v piece in behind the pipe and glue in place with wood work glue, use spacing wedges to hold the 'v' piece in place while the adhesive sets.

**Warning:** Failure to properly line up the end joint and attempting to force it in while out of alignment could result in permanent damage to the end joint.

### Installing the Last Row

1. The last row of the installation will need to be cut lengthwise.
2. Place the row of planks to be fitted on top of the last row of installed planks. Use a piece of the plank as a scribe to trace with a pencil the contour of the wall (See figure 6). The width of the last board should be at least 50 mm.
3. Cut the board to fit using the table saw and allow for the required expansion space.
4. Lay the piece into position (you may need to use a pull bar to tighten the joints).
5. If skirting's were removed reinstall over the top of the expansion gap.
6. Where skirting's were not removed install quarter round.

Figure 6

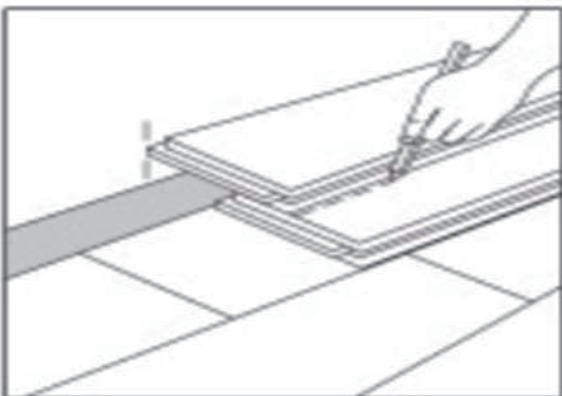



### **Edge finishing**

1. If skirting's were removed reinstall over the top of the expansion gap (do not fix skirting to the flooring, fix to the wall).
2. Where skirting's were not removed install quarter round or scotia (do not fix skirting to the flooring, fix to the wall).

### **Transitions**

The use of transitions (expansion joints) is not required for floor areas up to 400 m<sup>2</sup>, however no single dimension (width or length) in one area should exceed 20 metres in one direction.

### **Disassembly**

Separate the whole row by lifting it up delicately at an angle. To separate the planks, leave them flat on the ground and slide them apart.

Armstrong Flooring Pty Ltd  
29 - 39 Mills Road, Braeside, 3195 Victoria Australia  
For further information and samples:  
Australia Freecall 1800 632 624

Email [customer\\_services@armstrongflooring.com](mailto:customer_services@armstrongflooring.com) or contact us on the web  
[www.armstrongflooring.com.au/residential](http://www.armstrongflooring.com.au/residential)